



**SPRING END
GRINDING MACHINES**

**FEDERENDSCHLEIF-
MASCHINEN**

MOLATRICI PER MOLLE

**MACHINES À MEULER
LES RESSORTS**

**ЗАТОЧНЫЕ СТАНКИ
ДЛЯ ПРУЖИН**

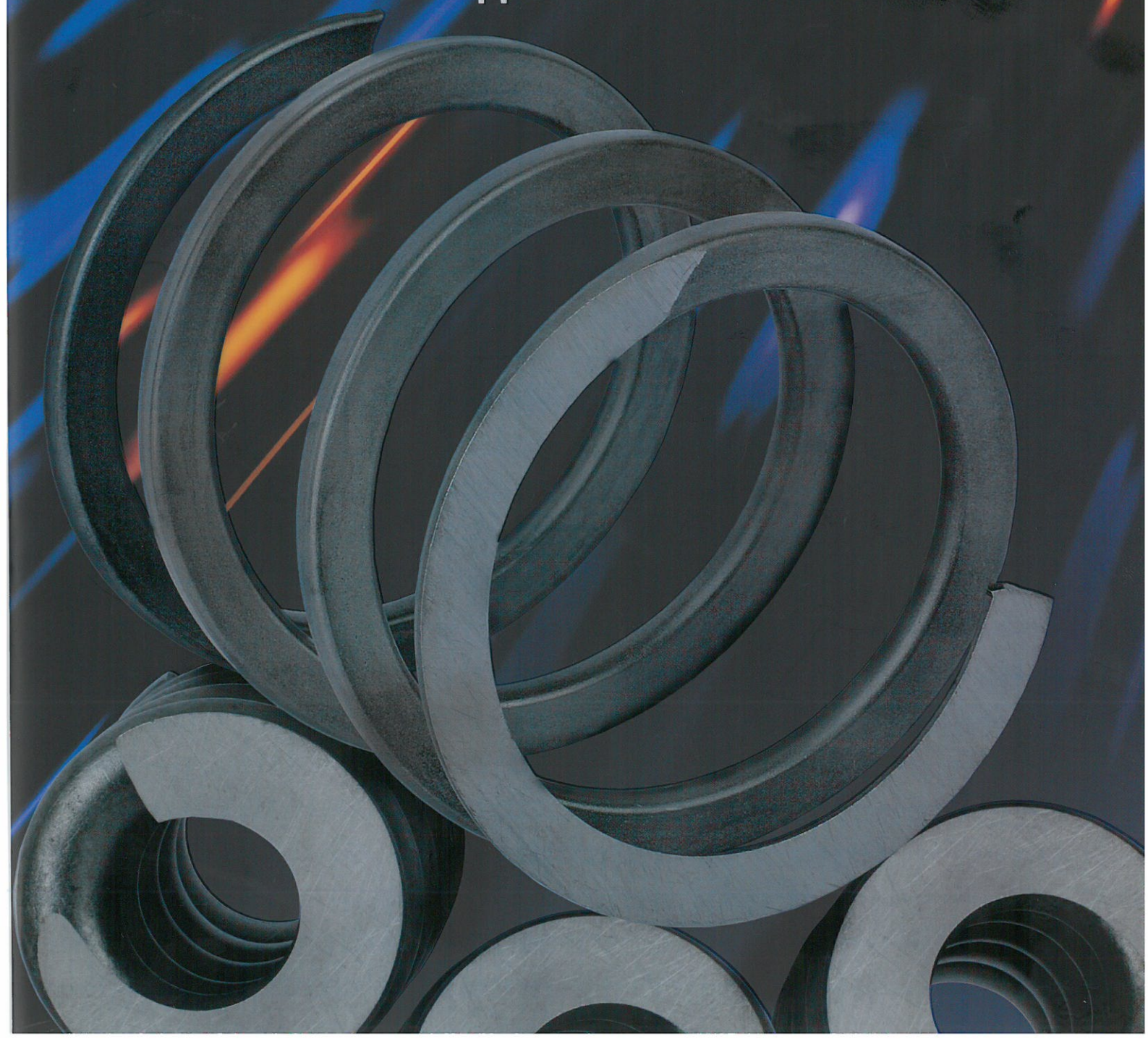

**MIT AUTOMATISCHEM SCHLEIFZYKLUS - WITH AUTOMATIC GRINDING CYCLE
 A CICLO AUTOMATICO - AVEC CYCLE AUTOMATIQUE - АВТОМАТИЧЕСКИЙ ЦИКЛ ШЛИФОВАНИЯ**

HA 100-2

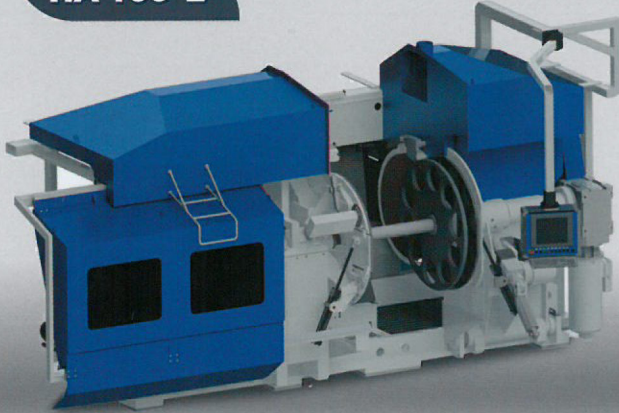

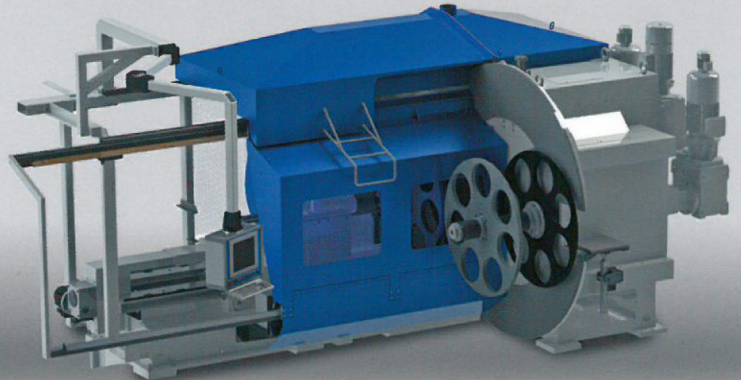

HA 100-2/2



HA 100-2

 \emptyset	1000 mm
$d\emptyset$	max 50 mm
$Da\emptyset$	max 320 mm
Lo 	1050 mm
kW	2 x 75
 \emptyset	1240 mm

HA 100-2/2

 \emptyset	1000 mm
$d\emptyset$	max 50 mm
$Da\emptyset$	max 320 mm
Lo 	1050 mm
kW	2 x 75
 \emptyset	1240 mm

H 110-1

 \emptyset	1100 mm
$d\emptyset$	60 mm
$Da\emptyset$	40 - 480 mm
Lo 	max 1200 mm con protezioni
kW	1 x 90

H 150

 \emptyset	1500 mm
$d\emptyset$	max 100 mm
$Da\emptyset$	40 - 800 mm
Lo 	max 1800 mm con protezioni
kW	1 x 110

We supply robotised and high production automatic loading devices

Wir liefern automatische Hochleistungs-Ladevorrichtungen und auch mit Roboter

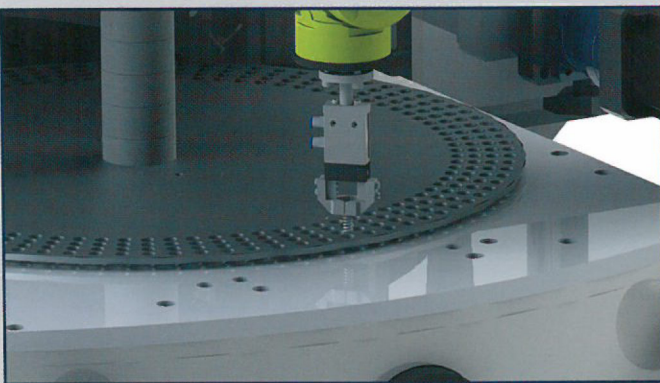

Forniamo caricatori automatici robotizzati e ad alta produzione

**Nous fournissons dispositifs de chargement automatique robotisés et à production élevée
 Мы поставляем роботизированные и высокопроизводительные автоматические загрузочные устройства**

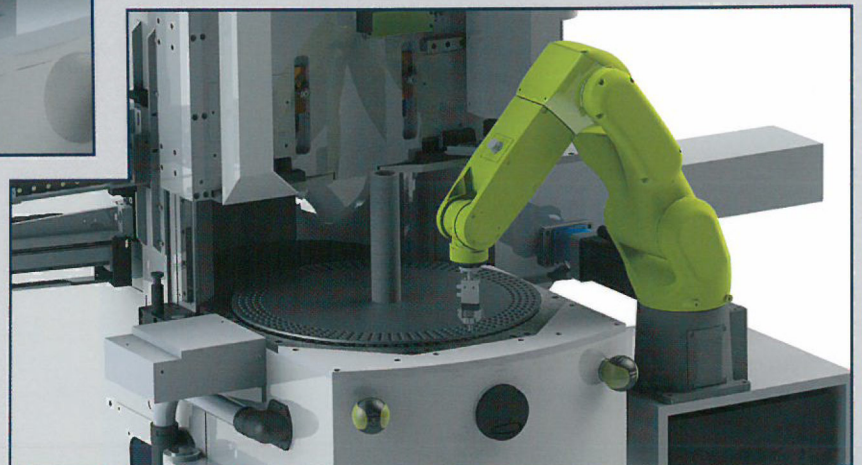

WITH WATER COOLING - MIT WASSERKÜHLUNG - CON RAFFREDDAMENTO AD ACQUA - AVEC REFROIDISSEMENT À EAU - С СИСТЕМОЙ ОХЛАЖДЕНИЯ ВОДОЙ

H 100-1

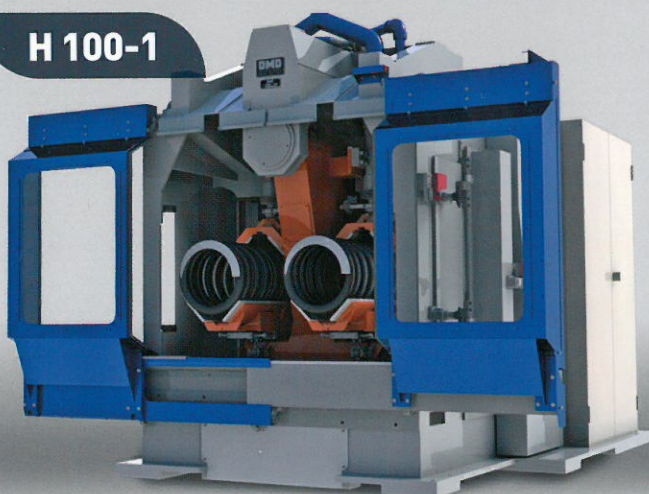

H 110-1

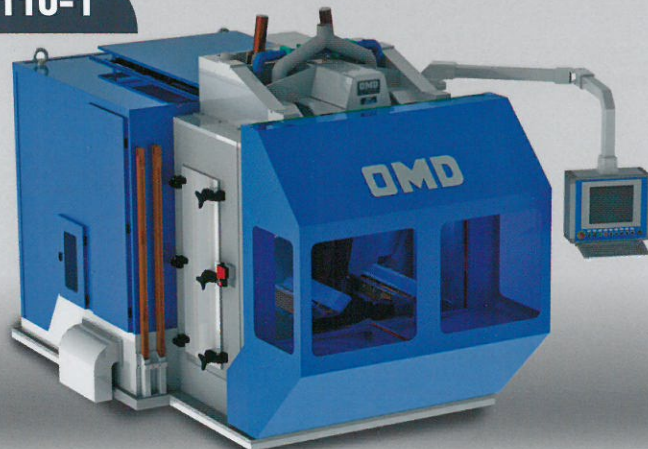

H 50

 \varnothing	500 mm
$d\varnothing$	max 30 mm
$Da\varnothing$	Max 250 mm
Lo 	400 mm
kW	1 x 22

H 80

 \varnothing	800 mm
$d\varnothing$	max 40 mm
$Da\varnothing$	40 - 330 mm
Lo 	max 800 mm con protezioni
kW	1 x 37

H 100

 \varnothing	1000 mm
$d\varnothing$	max 50 mm
$Da\varnothing$	40 - 400 mm
Lo 	max 800 mm con protezioni
kW	1 x 75

H 100-1

 \varnothing	1000 mm
$d\varnothing$	50 mm
$Da\varnothing$	40 - 400 mm
Lo 	max 1200 mm con protezioni
kW	1 x 75

**AUSSENTGRAT-
UND INNENENTGRATMASCHINEN**

**SPRING OUTSIDE AND INSIDE CHAMFERING MACHINES
SMUSSATRICI ESTERNE ED INTERNE PER MOLLE**

**MACHINES POUR LE CHAMFREINAGE
INTERIEUR ET EXTERIEUR**

**СТАНОК ДЛЯ СНЯТИЯ ВНУТРЕННЕЙ И
ВНЕШНЕЙ ФАСКИ ПРУЖИН**

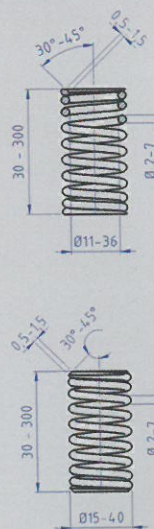
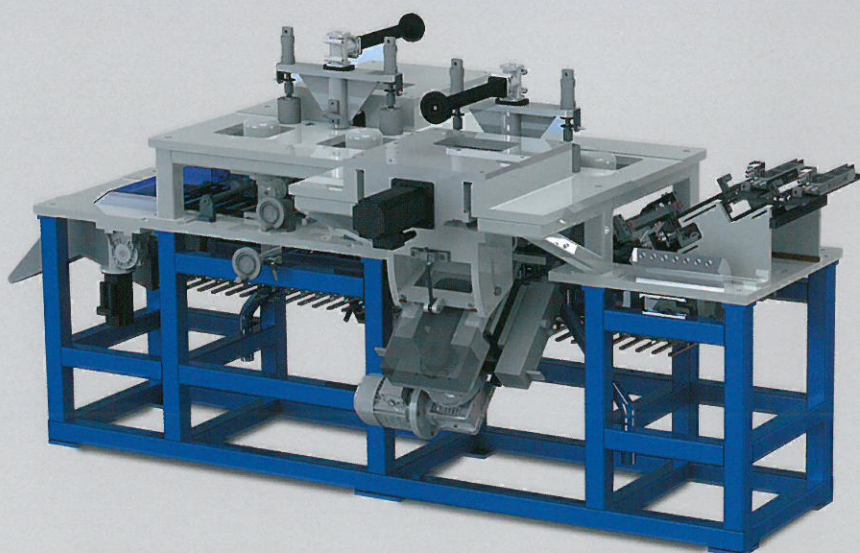

FG1/A 4F

$d\varnothing$	2-7 mm
$Da\varnothing$	15-40 mm
$Di\varnothing$	11-36 mm
Lo 	30-300 mm
	30° - 45°

FG1

FG2

FG3

FG/A-L



FG/A-3S

FG/A-S

FGA 1

FGA 2

FGA 3

Lo 	(6) 8 - 25 mm	20-50 mm	20-60 mm	15-30 mm	20-60 mm	15-50 mm	(6) 8-25 mm	15 - 40 mm	35-80 mm
kW	10 - 80 mm	20-100 mm	30-160 mm	150-400 mm	20-150 mm	20-100 mm	10-60 mm	20-100 mm (400)	45-300 mm
	45°	45°	45°	Est. 45° Int. 55°-65°	45°	30° - 45°	30° - 60°	30° - 60°	30° - 75°



DOWNFEED GRINDING

ZUSTELLSCHLIFF

A DISCESA AUTOMATICA



MA 6 - 1E



 \emptyset	400 mm	Lo 	220 mm + (200-500)
d \emptyset	0,5 - 6 mm	kW	2 x 2,2
Da \emptyset	Max 80 mm	 \emptyset	580 - 420 mm + (320-250)

MA9 - 1E



 \emptyset	450 mm	Lo 	400 mm
d \emptyset	1-9 mm	kW	2 x 7
Da \emptyset	Max 100 mm	 \emptyset	740 - 580 mm

MA 6 - 2E



 \emptyset	400 mm	Lo 	220 mm
d \emptyset	0,5 - 6 mm	kW	2 x 2,2
Da \emptyset	Max 80 mm	 \emptyset	420 mm

MA 9 - 2E



 \emptyset	450 mm	Lo 	400 mm
d \emptyset	1-9 mm	kW	2 x 7
Da \emptyset	Max 100 mm	 \emptyset	580 mm

AVEC DESCENTE AUTOMATIQUE

С АВТОМАТИЧЕСКОЙ ПОДАЧЕЙ ШПИНДЕЛЯ

MA 10 - 1E



	660 mm		370-500-700 mm
	2-13 mm		2 x 10
	Max 140 mm		740 mm

MA 16 - 1E

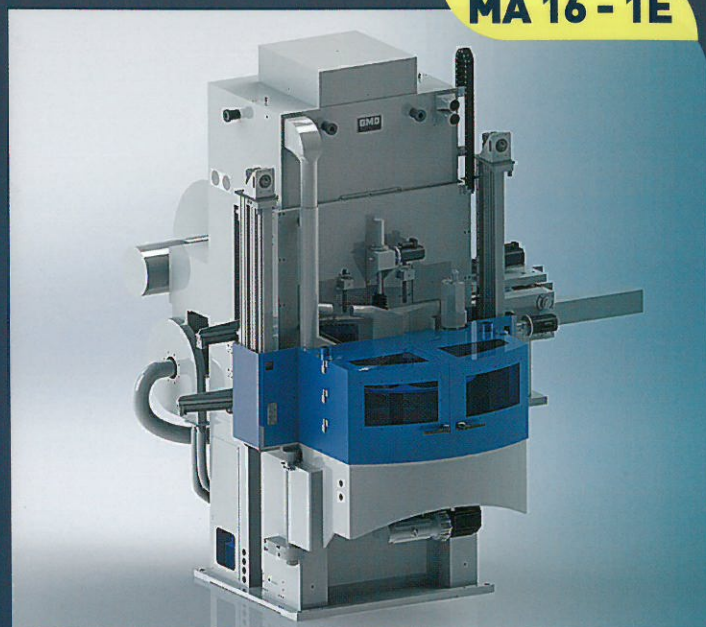

	915 mm		500-700-800 mm
	2-16 mm		2 x 20
	Max 250 mm		1040 mm



MA 10 - 2E



	660 mm		370-500-700 mm
	2-13 mm		2 x 10
	Max 140 mm		740 mm

MA 16 - 2E

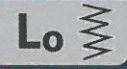

	915 mm		500-700-800 mm
	2-16 mm		2 x 20
	Max 200 mm		1040 mm

**CONTINUOUS
GRINDING**

**DURCHLAUF-
SCHLIFF**

**AD UN
PASSAGGIO**

**À UN SEUL
PASSAGE**

**ЗА ОДИН
ПРОХОД**

M1

 \emptyset	150 mm
$d\emptyset$	0,2-1 mm
$Da\emptyset$	Max 20 mm
Lo 	50 mm
kW	2 x 0,36
 \emptyset	180 mm



M2 CBN

 \emptyset	400 mm
$d\emptyset$	0,3-1 mm
$Da\emptyset$	Max 60 mm
Lo 	120 mm
kW	2 x 2,2
 \emptyset	420 mm



M3 S

 \emptyset	225 mm
$d\emptyset$	0,4-2 in passata 2-3 in + passate
$Da\emptyset$	Max 40 mm
Lo 	100 mm
kW	2 x 1,5
 \emptyset	320 - 250 mm

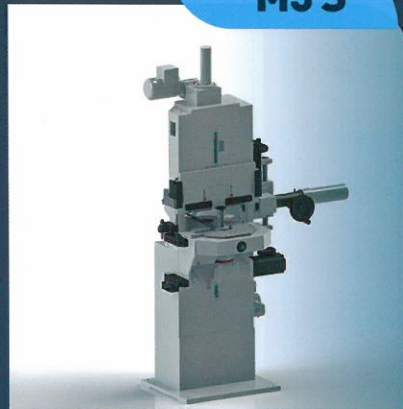

M4D CBN

 \emptyset	400 mm
$d\emptyset$	0,3-2 mm
$Da\emptyset$	Max 70 mm
Lo 	Max 120 mm
kW	4 x 2,2
 \emptyset	740 mm



M6 S

 \emptyset	400 mm
$d\emptyset$	0,5 - 3,5 mm
$Da\emptyset$	Max 80 mm
Lo 	220 mm
kW	2 x 2,2
 \emptyset	580-420 mm + (320-250)



M6 D

 \emptyset	400 mm
$d\emptyset$	0,5 - 3,5 mm
$Da\emptyset$	Max 80 mm
Lo 	Max 220 mm
kW	4 x 2,2
 \emptyset	740 mm

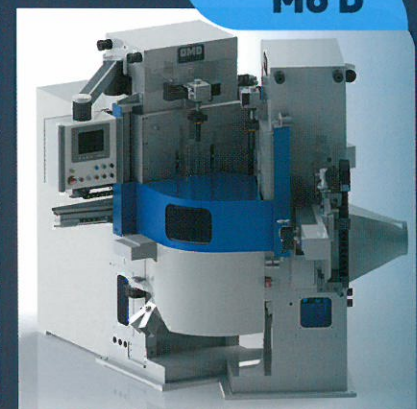

M9

 \emptyset	450mm
$d\emptyset$	1 - 3 mm
$Da\emptyset$	Max 100 mm
Lo 	400 mm
kW	2 x 7
 \emptyset	740 - 580 mm

M10

 \emptyset	660 mm
$d\emptyset$	1 - 4 mm
$Da\emptyset$	Max 140 mm
Lo 	370-500-700 mm
kW	2 x 10
 \emptyset	740 mm

M16

 \emptyset	915 mm
$d\emptyset$	1 - 5 mm
$Da\emptyset$	Max 250 mm
Lo 	500-700-800 mm
kW	2 x 20
 \emptyset	1040 mm